

CHRISTIE DAVIS

DESIGN

ARTWORK QUICK FACTS FOR NON-DESIGNERS

FILE TYPES



jpg

- compressed photoshop file
- easy to send via email
- can be inserted into any document for printing when saved at reasonable size
- always contains a white or coloured background



png

- photoshop file
- easy to send via email
- can be inserted into any document for printing when saved at reasonable size
- contains transparent background



psd

- photoshop file
- large, layered file not suitable for emailing
- artwork can be altered
- file to be sent via programs such as wetransfer and dropbox



tiff

- photoshop file
- large, flat file not suitable for emailing
- file to be sent via programs such as wetransfer and dropbox



eps + ai

- illustrator file (also called vector artwork)
 - can be blown up to any size without losing quality
 - examples include logos, diagrams, illustration work
 - fonts may or may not be outlined*
- * If fonts are not outlined they will default. Request outlined fonts.



pdf

- compressed artwork file
- easy to send via email
- print ready and web ready options

Note: Always double check with your designer if a file is print ready before passing onto a printer.

WHAT ARE 'WORKING FILES'?

If you need to request 'working files' the designer will provide a "packaged" file which includes all the elements you will need to open the artwork, change the artwork and send it to print. Only accessible if you have Adobe programs. All printers will have these programs.

CHRISTIE DAVIS

DESIGN

COMMON PRINT SIZES

DL 2PP
2 printed sides



99mm 210mm

DL 4PP
4 printed sides

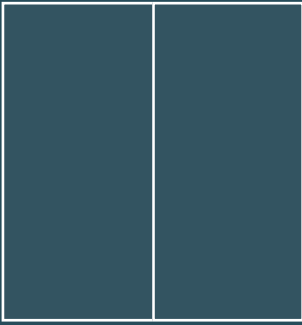

99mm 99mm 210mm

DL 6PP*
6 printed sides

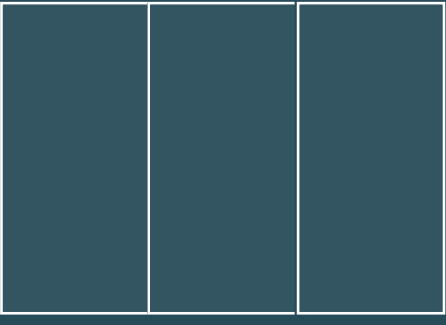

99mm 99mm 99mm 210mm

A4 2PP
2 printed sides



210mm 297mm

A4 4PP
4 printed sides



210mm 210mm 297mm

A4 6PP*
6 printed sides



210mm 210mm 210mm 297mm

* TWO FOLD OPTIONS AVAILABLE FOR THESE SIZES

ROLL FOLD



Z FOLD (OR
CONCERTINA
FOLD)



CHRISTIE DAVIS

DESIGN

STOCK THICKNESS

90-120gsm

- letterheads, with compliments slips
- light weight flyers
- inside pages of a publication

150gsm

- DL brochures
- A4 brochures (up to 8pp size)
- inside pages of a publication

300-350gsm

- business cards
- publication covers
- postcards

STOCK TYPE

Satin

- low sheen finish
- smooth to touch

Gloss

- high sheen finish
- smooth to touch

Uncoated

- matt finish
- may feel slightly textured

STOCK COATING

Machine Varnish

- sealed finish which prevents ink from transferring or bleeding
- standard finish to all print jobs

Matt or gloss laminate

- thick coating applied in a matt or gloss finish
- adds thickness and protection to the stock

Foil or spot varnish

- specialty finish applied to areas of artwork to add emphasis